



ⓓ Btx * 32700 #

Ergänzung
Supplement

TVR 3701 SV

Sach-Nr./Part No.
72010-524.96

Zusätzlich erforderliche Unterlagen für den Komplettservice:

Additionally required Service Manuals for the Complete Service:

Service Manual

Sicherheit
Safety

Sach-Nr./Part No.
72010-800.00

Service Manual

TVR 3710 ...
TVR 5100 ...
TVR 5500 ...

Sach-Nr./Part No.
72010-524.95

TVR 3701 SV

TVR 3701 SV (77250-012.52 / G.CD 4352) TVP 762
(77250-015.52 / G.CD 6352) TVP 762
(77250-016.52 / G.CD 6452) TVP 762

ⓓ

ⓖⓑ

In dieser Service-Manual-Ergänzung sind die Unterschiede der Geräte TVR 3701 SV zu den Geräten des Basis-Service-Manuals TVR 3710 ..., TVR 5100 ..., TVR 5500 ... dokumentiert.

Hinweis: Grundlage für den Service sind folgende Service Manuals:

- Sicherheit, Sach-Nummer 72010-800.00
- Service Manual, Sach-Nummer 72010-524.95

Die Bausteinbestückung und die Sach-Nummern der einzelnen Komponenten entnehmen Sie bitte der Ersatzteillisten.

This Supplement Service manual describes the differences between the TVR 3701 SV and the TVR 3710 ..., TVR 5100 ..., TVR 5500 ... dealt with in the Main Service Manual.

Note: Basic instructions for servicing are given in the following Service Manuals:

- Safety, part no. 72010-800.00
- Service Manual, part no. 72010-524.95

For the individual modules and for the spare part numbers of the modules, please see the spare parts lists.

Inhaltsverzeichnis

	Seite
Allgemeiner Teil	1
- Geräte-Codenummern	1
- Geräteübersicht	2
Schaltpläne und Platinenabbildungen	3
- Signal-Chassis (PSSPM)	3
- Bedieneinheit (CO)	8
- IN/OUT (IO)	11
Ersatzteillisten	13

Table of Contents

	Page
General Section	1
- TVR Code Numbers	1
- TVR Overview	2
Layout of the PCBs and Circuit Diagrams	3
- Signal Chassis (PSSPM)	3
- Keyboard Control Unit (CO)	8
- IN/OUT (IO)	11
Spare Parts Lists	13

Allgemeiner Teil

Geräte-Codenummer

General Section

TVR Code Numbers

	Best-Nr. / Order No.	Option-Code
TVR 3701 SV	G.CD 4352	00973
	G.CD 6352	00973
	G.CD 6452	00973



PAL

Geräteübersicht / TVR Overview

	Ergänzung / Supplement	Service Manual Sach-Nr./Part No. 71010-524.95			TVR 3701 SV
Geräte-Bausteinübersicht Table of Modules		S./P 4-18	Netzschalterplatte / Power Switch Board	—	
		S./P 4-19	Leistungs-Chassis / Power PCB (PLSP)	—	●
		S./P 4-33	Bildrohrplatte / Tube PCB	—	●
		S./P 4-46	Laufwerkplatte-Sensoreinheit / Tape Deck Sensor Panel	75988-018.22	●
	S./P 3 S./P 8		Signal-Chassis (PSSPM) • Bedieneinheit / Keyboard Control Unit (CO) • Laufwerksteuerung / Deck Control/Deck Electronic (DE)		
	S./P 11	S./P 4-49 S./P 4-51	• TV-Signalelektronik / TV Signal Electronics (TV) • IN/OUT (IO)	—	●
		S./P 4-61 S./P 4-65	• Video/Chroma (VS) • Standardton / Standard Sound (AL)		
		S./P 4-68	Buchsenplatte / Socket Board (BUPI)	—	
	S./P 4-69	Kopfverstärker / Head Amplifier (OHA)	27599-004.07	●	
Geräte-Feature-Übersicht Table of Features	CCIR, B/G/H - PAL				●
	CCIR, I - PAL				
	CCIR, B/G/L/L' - SECAM				
	NTSC-Wiedergabe / NTSC Playback				●
	2 Empfangseinheiten / Frontend (Tuner)				
	Bildschirmdiagonale 37cm (sichtbares Bild: 34cm) / Screen diagonale 37cm (visible picture: 34cm)				●
	Bildschirmdiagonale 51cm (sichtbares Bild: 48cm) / Screen diagonale 51cm (visible picture: 48cm)				
	Bildschirmdiagonale 55cm (sichtbares Bild: 51cm) / Screen diagonale 55cm (visible picture: 51cm)				
	Ablenkwinkel / Deflection angle 90				●
	High Speed Drive (HSD)				
	2-Kopf/Head				●
	Normalplay				●
	Longplay				
	VISS				●
	ATS euro plus				●
	"On Screen Display" (OSD)				●
	VPS				● 1)
	PDC				
	Teletext "DOS"				
	SHOW VIEW				●
	VIDEO Plus				
	6 Timer				●
	69 Programme + 1 AV				●
Kopfhörerbuchse / Headphone Jack				●	
EURO-AV-Buchse / Socket				●	
LINE/CV-Buchsen / Sockets					

1) nur für Version / only for version G.CD 4352

Platinenabbildungen und Schaltpläne / Layout of PCBs and Circuit Diagrams

Signal-Chassis (PSSPM)

Ansicht von der Bestückungsseite / View of Component Side

0002 F 1	2511 H 9	3823 H 2	6803 H 3	9082 F 7	9195 J 6
0003 G 1	2513 E 1	3824 J 4	6804 J 4	9083 F 7	9196 J 1
0004 A 1	2514 H10	3825 H 2	6805 H 4	9084 E 7	9197 K 4
0006 J13	2605 H12	3829 H 3	6830 G 4	9085 E 7	9198 F 5
1000 B 5	2609 I 11	3830 H 4	6863 A 1	9086 E 8	9199 I 9
1001 E14	2611 I 11	3831 H 4	6868 G 1	9087 E 8	9200 I 9
1002 E14	2614 I 12	3835 D 1	6869 F 1	9088 H10	9201 H 1
1003 D14	2615 I 12	3838 I 4	7006 D 8	9089 D10	9202 H 9
1004 D13	2616 J12	3853 C 1	7051 B 5	9090 D 4	9203 F 8
1200 K 8	2617 I 13	3856 C 1	7070 C 4	9091 D 5	9204 F 8
1301 B14	2619 I 13	3868 D 1	7151 B 8	9092 E 9	9205 D 5
1320 C13	2620 H13	3869 D 1	7200 J 9	9093 D 4	9206 G 4
1322 A13	2622 H13	3878 G 1	7201 K 7	9095 E 7	9207 B10
1324 C13	2654 J13	3879 F 1	7202 K 7	9096 E 6	9208 G 2
1340 B11	2659 I 14	3898 G 2	7240 J13	9097 F11	9209 L14
1345 B12	2690 F10	5000 D 9	7280 K12	9098 D 2	9210 E14
1346 B11	2701 L12	5001 A 4	7402 D13	9099 E 6	9211 I 7
1400 F 3	2712 J10	5002 D 8	7410 C 3	9100 E 6	9212 I 7
1501 E14	2713 K10	5003 B 6	7411 D11	9101 E 6	9213 H 4
1502 H 5	2715 H 7	5004 C 7	7491 E12	9102 E 5	9214 C 7
1701 K13	2733 I 8	5005 D 7	7601 I 12	9103 F 5	9215 K 10
1702 K13	2740 J11	5006 C 6	7604 I 13	9104 F 5	9216 E10
1720 K 9	2742 K 8	5007 D 6	7608 I 13	9105 F 5	9217 D14
1732 K 9	2743 K 8	5008 C 6	7690 E10	9106 F 5	9218 F 4
1740 H 8	2744 K 7	5009 A 7	7754 K 8	9107 E 2	9219 G 6
1745 I 9	2748 I 7	5010 A 7	7801 I 3	9108 F 3	9220 G 6
1746 I 9	2801 H 5	5011 A 8	7812 B 1	9109 G 2	9221 G 5
1750 L 8	2802 G 3	5012 C 6	7813 C 2	9110 G 2	9222 G 5
1800 L 2	2805 H 7	5013 C 6	7840 B 2	9111 F 5	9223 G 5
1801 I 3	2808 H 3	5014 C 7	7870 K 2	9112 G 5	9224 I 7
1802 J 3	2810 J 7	5015 A 4	7880 L 3	9113 H 8	9225 H 6
1803 J 3	2811 J 7	5100 B 8	7881 L 3	9114 G 6	9226 H 6
1804 G 5	2814 J 3	5101 B 8	9000 A12	9115 E14	9227 I 1
1850 G 1	2815 B 1	5102 A 8	9001 C11	9116 G 9	9228 I 6
1851 J 1	2881 K 1	5103 A 9	9002 D14	9117 I 11	9229 I 10
1852 A 1	3005 A 4	5104 A 9	9003 D13	9118 H 6	9230 E 9
1853 E 1	3010 A 6	5105 A 8	9004 C12	9119 F 7	9231 B12
1854 H 1	3011 A 6	5106 C 7	9005 B 3	9120 F14	9232 D10
1855 I 1	3020 A 7	5107 C 8	9006 B 4	9121 H 5	9233 K 2
1856 C 1	3027 A 7	5108 C 9	9007 B 4	9122 G 9	9234 E13
1857 H 1	3028 A 8	5110 C 8	9008 C 4	9123 H 7	9235 L14
1858 I 1	3029 B 7	5111 C 8	9009 E 9	9124 K14	9236 K 4
1859 K 1	3030 B 6	5112 C 8	9010 C 4	9125 K14	9290 D 1
1860 D 1	3031 D 5	5113 C 8	9011 C 4	9126 J14	9301 A12
1861 E 1	3071 C 4	5114 C 8	9012 C 5	9127 K13	9302 C11
1900 G13	3114 C10	5115 D 9	9014 I 9	9128 L13	9303 C14
1901 G13	3115 C 7	5200 H 6	9015 A 6	9129 L12	
1902 A11	3202 L11	5201 I 6	9016 B 6	9130 J 6	
1903 E13	3206 K14	5202 I 6	9017 C 4	9131 L 5	
1904 E13	3207 L 9	5203 I 6	9018 D 5	9132 I 10	
1905 F13	3214 J 4	5300 A13	9019 E 8	9133 G 4	
1907 J 1	3218 K 6	5301 B13	9020 B 7	9134 G 2	
1908 J 1	3220 J 7	5302 B13	9021 C 5	9135 H 2	
1909 E14	3235 J 2	5303 B12	9022 C 9	9136 H 2	
1911 L10	3236 J 2	5304 A13	9023 K 9	9137 H 2	
1912 L13	3237 J 2	5305 B13	9024 E 8	9138 H 2	
1913 L 6	3244 L 1	5307 B11	9025 D 5	9139 H 2	
1914 K14	3249 K 1	5401 F 5	9026 D 7	9140 D 2	
1915 H14	3250 J12	5402 F13	9027 D 7	9141 H 8	
1916 L 1	3270 G10	5601 I 12	9028 D 8	9142 F 6	
1918 A 1	3306 D14	5602 G13	9029 D 8	9143 J 6	
1970 L14	3322 C12	5603 H13	9030 D 7	9144 F 7	
1971 L13	3329 C11	5700 J12	9031 C 5	9145 G 9	
1972 C 2	3341 C13	5701 K10	9033 B 1	9146 H 9	
1973 F 7	3403 F 3	5702 K10	9034 D 3	9147 H 8	
2004 C 5	3408 F 3	5703 K10	9035 D 3	9148 H 9	
2005 C 5	3410 F 2	5704 K10	9037 D11	9149 G 6	
2007 C 5	3412 F 2	5705 J10	9038 E 6	9150 G 6	
2009 C 5	3414 F 2	5706 I 8	9039 D 7	9151 K 4	
2015 A 4	3416 F 2	5707 K10	9040 E 7	9152 L 8	
2016 B 3	3418 F 2	5801 I 5	9041 B10	9153 J 6	
2017 A 4	3420 F 2	5840 C 5	9042 G 5	9155 L14	
2018 A 5	3423 D 3	5841 B 1	9043 G 6	9156 I 11	
2020 A 5	3425 D 3	5880 L 1	9044 H 5	9157 J 6	
2022 A 5	3427 D 5	5881 L 2	9045 B10	9158 H 5	
2023 A 5	3433 F 3	5882 H 6	9046 C10	9159 J11	
2027 A 6	3434 D 3	6000 A 6	9047 C10	9160 F 1	
2029 B 6	3435 E 6	6070 C 4	9048 D 9	9161 I 1	
2058 C 9	3436 F 5	6200 H 7	9049 D 8	9162 I 2	
2059 C 9	3438 F 4	6202 I 10	9050 E 8	9163 I 2	
2061 A 3	3440 F 4	6203 H10	9051 D10	9164 I 1	
2065 B 2	3441 F 3	6205 F11	9052 E13	9165 I 2	
2136 C 9	3447 D 3	6208 J 5	9053 E 7	9166 J 2	
2200 K 9	3448 D12	6242 K13	9054 F12	9167 J 2	
2203 K 8	3452 D13	6261 J 5	9055 F14	9168 J 2	
2219 J 7	3461 D 4	6262 K 6	9056 H10	9169 J 4	
2223 I 8	3462 F12	6263 J 5	9057 C11	9170 K 1	
2224 H 8	3463 E11	6280 F10	9058 F12	9171 J 3	
2229 J 9	3470 F 4	6401 G13	9059 F12	9172 K 4	
2230 K 8	3473 F 4	6500 H14	9060 D12	9173 K 4	
2231 I 8	3478 D 4	6503 I 14	9061 F11	9174 I 6	
2242 L12	3494 E12	6504 H14	9062 F11	9175 I 14	
2244 J11	3495 E12	6505 G14	9063 D12	9176 I 9	
2251 G14	3515 G 8	6506 H14	9064 F 9	9177 J 4	
2300 C13	3517 G10	6507 G14	9065 E 9	9178 K 5	
2301 D14	3526 G 8	6508 H14	9066 F11	9179 K 5	
2311 D14	3539 J14	6509 G14	9067 F10	9180 K 5	
2316 C12	3606 H12	6510 H14	9068 D10	9181 J 5	
2320 A12	3618 H12	6512 G 8	9069 D10	9182 L 6	
2322 B13	3661 J14	6513 G 8	9070 D10	9183 L 6	
2324 A13	3690 F11	6514 G 9	9071 H13	9184 K 6	
2401 E 5	3703 L11	6515 G 7	9072 J12	9185 L 5	
2430 D13	3704 L11	6516 A 1	9073 G 6	9186 L 5	
2450 E11	3712 K10	6517 A 1	9074 J12	9187 K 8	
2452 D12	3729 K11	6690 E10	9075 H 8	9188 K 7	
2455 D12	3740 J10	6691 F10	9076 F 9	9189 K 7	
2470 F14	3743 I 6	6692 F10	9077 F 9	9190 J14	
2491 F13	3772 K11	6693 F10	9078 F 8	9191 K11	
2501 I 14	3811 J 4	6694 F10	9079 F 9	9192 K12	
2508 H 7	3816 H 4	6801 G 5	9080 F 8	9193 K12	
2510 G 8	3822 H 5	6802 G 3	9081 F 7	9194 J 6	

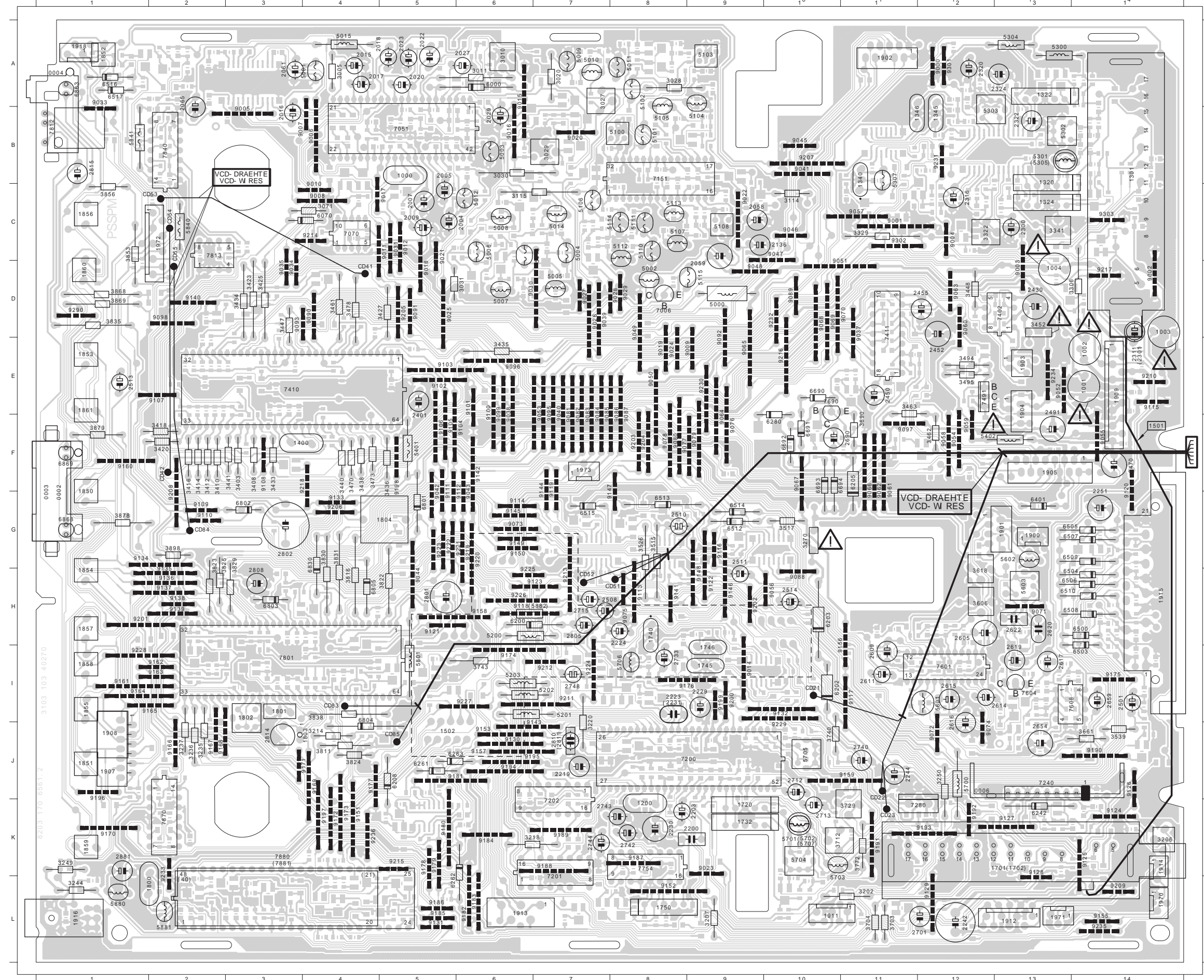

Signal-Chassis (PSSPM)

Ansicht von der Lötseite / View of Solder Side

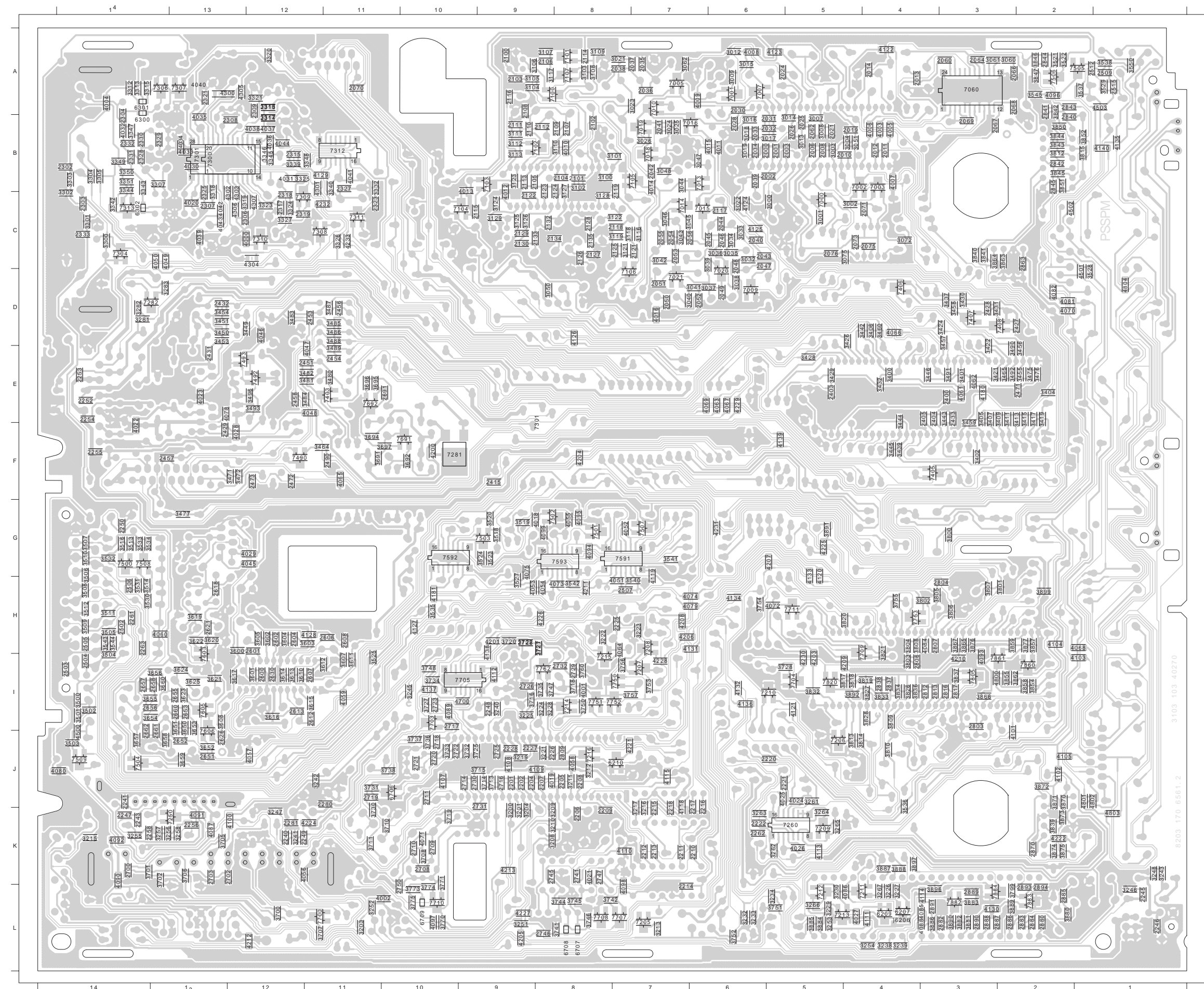

0002 F 1	2511 H 9	3823 H 2	6803 H 3	9082 F 7	9195 J 6
0003 G 1	2513 E 1	3824 J 4	6804 J 4	9083 F 7	9196 J 1
0004 A 1	2514 H10	3825 H 2	6805 H 4	9084 E 7	9197 K 4
0006 J 13	2605 H12	3829 H 3	6830 G 4	9085 E 7	9198 F 5
1000 B 5	2609 I 11	3830 H 4	6863 A 1	9086 E 8	9199 I 9
1001 E14	2611 I 11	3831 H 4	6868 G 1	9087 E 8	9200 I 9
1002 E14	2614 I 12	3835 D 1	6869 F 1	9088 H10	9201 H 1
1003 D14	2615 I 12	3838 I 4	7006 D 8	9089 D10	9202 H 9
1004 D13	2616 J 12	3853 C 1	7051 B 5	9090 D 4	9203 F 8
1200 K 8	2617 I 13	3856 C 1	7070 C 4	9091 D 5	9204 F 8
1301 B14	2619 I 13	3868 D 1	7151 B 8	9092 E 9	9205 D 5
1320 C13	2620 H13	3869 D 1	7200 J 9	9093 D 4	9206 G 4
1322 A13	2622 H13	3878 G 1	7201 K 7	9095 E 7	9207 B10
1324 C13	2654 J 13	3879 F 1	7202 K 7	9096 E 6	9208 G 2
1340 B11	2659 I 14	3898 G 2	7240 J13	9097 F11	9209 L14
1345 B12	2690 F10	5000 D 9	7280 K12	9098 D 2	9210 E14
1346 B11	2701 L12	5001 A 4	7402 D13	9099 E 6	9211 I 7
1400 F 3	2712 J 10	5002 D 8	7410 E 3	9100 E 6	9212 I 7
1501 E14	2713 K10	5003 B 6	7411 D11	9101 E 6	9213 H 7
1502 H 5	2715 H 7	5004 C 7	7491 E12	9102 E 5	9214 C 4
1701 K13	2733 I 8	5005 D 7	7601 I 12	9103 E 5	9215 K 5
1702 K13	2740 J 11	5006 C 6	7604 I 13	9104 F 5	9216 E10
1720 K 9	2742 K 8	5007 D 6	7608 I 13	9105 F 5	9217 D14
1732 K 9	2743 K 8	5008 C 6	7690 E10	9106 F 5	9218 F 4
1740 H 8	2744 K 7	5009 A 7	7754 K 8	9107 E 2	9219 G 6
1745 I 9	2748 I 7	5010 A 7	7801 I 3	9108 F 3	9220 G 6
1746 I 9	2801 H 5	5011 A 8	7812 B 1	9109 G 2	9221 G 5
1750 L 8	2802 G 3	5012 C 6	7813 C 2	9110 G 2	9222 G 5
1800 L 2	2805 H 7	5013 C 6	7840 B 2	9111 F 5	9223 G 5
1801 I 3	2808 H 3	5014 C 7	7870 K 2	9112 G 5	9224 I 7
1802 I 3	2810 J 7	5015 A 4	7880 L 3	9113 H 8	9225 H 6
1803 J 3	2811 J 7	5100 B 8	7881 L 3	9114 G 6	9226 H 6
1804 G 5	2814 J 3	5101 B 8	9000 A12	9115 E14	9227 I 6
1850 G 1	2815 B 1	5102 A 8	9001 C11	9116 G 9	9228 I 1
1851 J 1	2881 K 1	5103 A 9	9002 D14	9117 I 11	9229 I 10
1852 A 1	3005 A 4	5104 A 9	9003 D13	9118 H 6	9230 E 9
1853 E 1	3010 A 6	5105 A 8	9004 C12	9119 F 7	9231 B12
1854 H 1	3011 A 6	5106 C 7	9005 B 3	9120 F14	9232 D10
1855 I 1	3020 A 7	5107 C 8	9006 B 4	9121 H 5	9233 K 2
1856 C 1	3027 A 7	5108 C 9	9007 B 4	9122 G 9	9234 E13
1857 H 1	3028 A 8	5110 C 8	9008 C 4	9123 H 7	9235 L14
1858 I 1	3029 B 7	5111 C 8	9009 E 9	9124 K14	9236 K 4
1859 K 1	3030 B 6	5112 C 8	9010 C 4	9125 K14	9290 D 1
1860 D 1	3031 D 5	5113 C 8	9011 C 4	9126 J14	9301 A12
1861 E 1	3071 C 4	5114 C 8	9012 C 5	9127 K13	9302 C11
1900 G13	3114 C10	5115 D 9	9014 I 9	9128 L13	9303 C14
1901 G13	3115 C 7	5200 H 6	9015 A 6	9129 L12	
1902 A11	3202 L11	5201 I 6	9016 B 6	9130 J 6	
1903 E13	3206 K14	5202 I 6	9017 C 4	9131 L 5	
1904 E13	3207 L 9	5203 I 6	9018 D 5	9132 I 10	
1905 F13	3214 J 4	5300 A13	9019 E 8	9133 G 4	
1907 J 1	3218 K 6	5301 B13	9020 B 7	9134 G 2	
1908 J 1	3220 J 7	5302 B13	9021 C 5	9135 H 2	
1909 E14	3235 J 2	5303 B12	9022 C 9	9136 H 2	
1911 L10	3236 J 2	5304 A13	9023 K 9	9137 H 2	
1912 L13	3237 J 2	5305 B13	9024 E 8	9138 H 2	
1913 L 6	3244 L 1	5307 B11	9025 D 5	9139 H 2	
1914 K14	3249 K 1	5401 F 5	9026 D 7	9140 D 2	
1915 H14	3250 J 12	5402 F13	9027 D 7	9141 H 8	
1916 L 1	3270 G10	5601 I 12	9028 D 8	9142 F 6	
1918 A 1	3306 D14	5602 G13	9029 D 8	9143 J 6	
1970 L14	3322 C12	5603 H13	9030 D 7	9144 F 7	
1971 L13	3329 C11	5700 J 12	9031 C 5	9145 G 6	
1972 C 2	3341 C13	5701 K10	9033 B 1	9146 H 9	
1973 F 7	3403 F 3	5702 K10	9034 D 3	9147 G 8	
2004 C 5	3408 F 3	5703 K10	9035 D 3	9148 H 9	
2005 C 5	3410 F 2	5704 K10	9037 D11	9149 G 6	
2007 C 5	3412 F 2	5705 J 10	9038 E 6	9150 G 6	
2009 C 5	3414 F 2	5706 I 8	9039 D 7	9151 K 4	
2015 A 4	3416 F 2	5707 K10	9040 E 7	9152 L 8	
2016 B 3	3418 F 2	5801 I 5	9041 B10	9153 J 6	
2017 A 4	3420 F 2	5840 C 2	9042 G 5	9155 L14	
2018 A 5	3423 D 3	5841 B 1	9043 G 6	9156 I 11	
2020 A 5	3425 D 3	5880 L 1	9044 H 5	9157 J 6	
2022 A 5	3427 D 5	5881 L 2	9045 B10	9158 H 5	
2023 A 5	3433 F 3	5882 H 6	9046 C10	9159 J 11	
2027 A 6	3434 D 3	6000 A 6	9047 C10	9160 F 1	
2029 B 6	3435 E 6	6070 C 4	9048 D 9	9161 I 1	
2058 C 9	3436 F 5	6200 H 7	9049 D 8	9162 I 2	
2059 C 9	3438 F 4	6202 I 10	9050 E 8	9163 I 2	
2061 A 3	3440 F 4	6203 H10	9051 D10	9164 I 1	
2065 B 2	3441 F 3	6205 F11	9052 E13	9165 I 2	
2136 C 9	3447 D 3	6208 J 5	9053 E 7	9166 J 2	
2200 K 9	3448 D12	6242 K13	9054 F12	9167 J 2	
2203 K 8	3452 D13	6261 J 5	9055 F14	9168 J 2	
2219 J 7	3461 D 4	6262 K 6	9056 H10	9169 J 4	
2223 I 8	3462 F12	6263 J 5	9057 C11	9170 K 1	
2224 H 8	3463 E11	6280 F10	9058 F12	9171 J 3	
2229 I 9	3470 F 4	6401 G13	9059 F12	9172 K 4	
2230 K 8	3473 F 4	6500 H14	9060 D12	9173 K 4	
2231 I 8	3478 D 4	6503 I 14	9061 F11	9174 I 6	
2242 L12	3494 E12	6504 H14	9062 F11	9175 I 14	
2244 J 11	3495 E12	6505 G14	9063 D12	9176 I 9	
2251 G14	3515 G 8	6506 H14	9064 F 9	9177 J 4	
2300 C13	3517 G10	6507 G14	9065 E 9	9178 K 5	
2301 D14	3526 G 8	6508 H14	9066 F11	9179 K 5	
2311 D14	3539 J 14	6509 G14	9067 F10	9180 K 5	
2316 C12	3606 H12	6510 H14	9068 D10	9181 J 5	
2320 A12	3618 H12	6512 G 9	9069 D10	9182 L 6	
2322 B13	3661 J 14	6513 G 8	9070 D10	9183 L 6	
2324 A13	3690 F11	6514 G 9	9071 H13	9184 K 6	
2401 E 5	3703 L11	6515 G 7	9072 J 12	9185 L 5	
2430 D13	3704 L11	6516 A 1	9073 G 6	9186 L 5	
2450 E11	3712 K10	6517 A 1	9074 J 12	9187 K 8	
2452 D12	3729 K11	6690 E10	9075 H 8	9188 K 7	
2455 D12	3740 J 10	6691 F10	9076 F 9	9189 K 7	
2470 F14	3743 I 6	6692 F10	9077 F 9	9190 J 14	
2491 F13	3772 K11	6693 F10	9078 F 8	9191 K11	
2501 I 14	3811 J 4	6694 F10	9079 F 9	9192 K12	
2508 H 7	3816 H 4	6801 G 5	9080 F 8	9193 K12	
2510 G 8	3822 H 5	6802 G 3	9081 F 7	9194 J 6	

Signal-Chassis – Bedieneinheit / Keyboard Control Unit (CO)

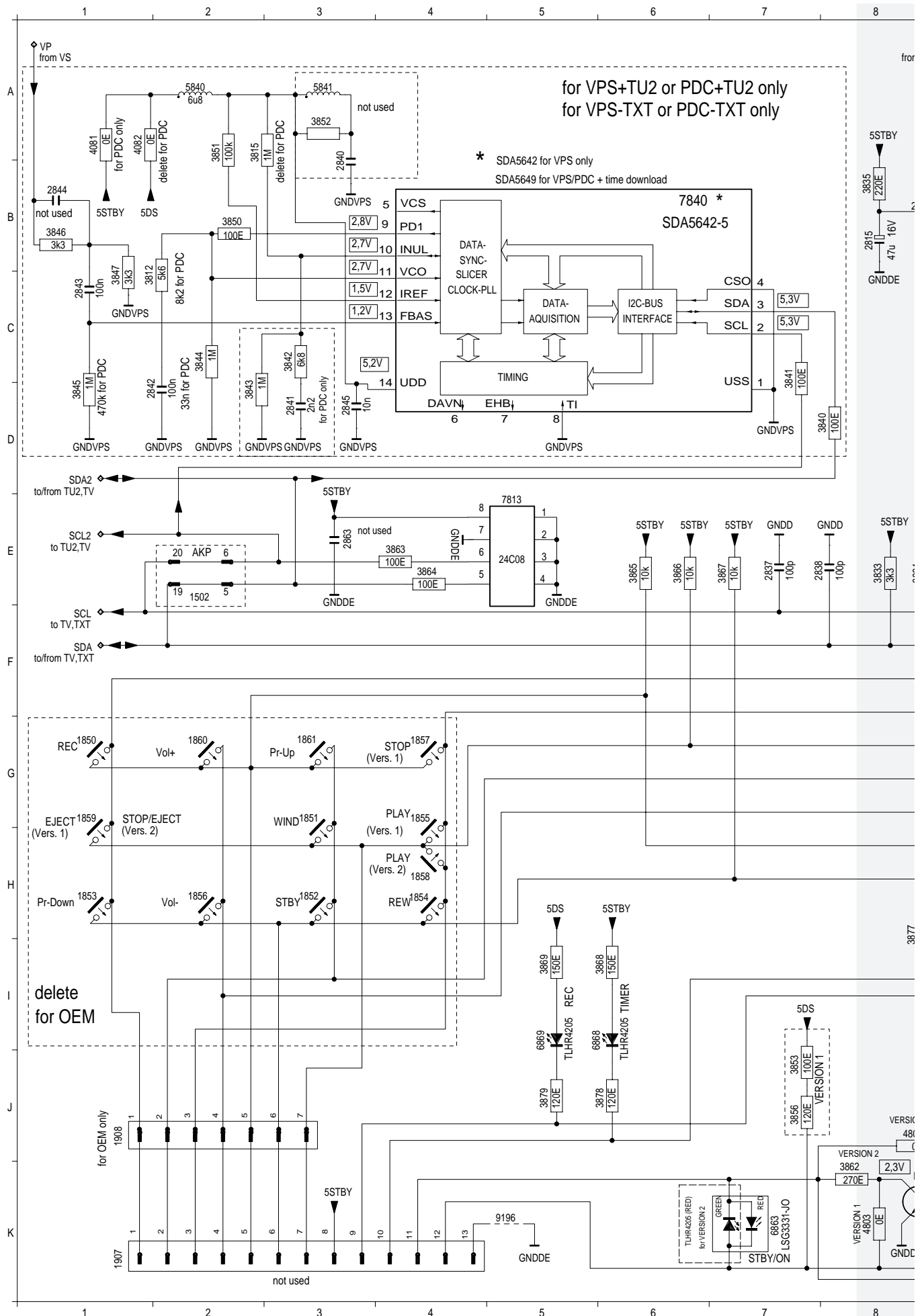

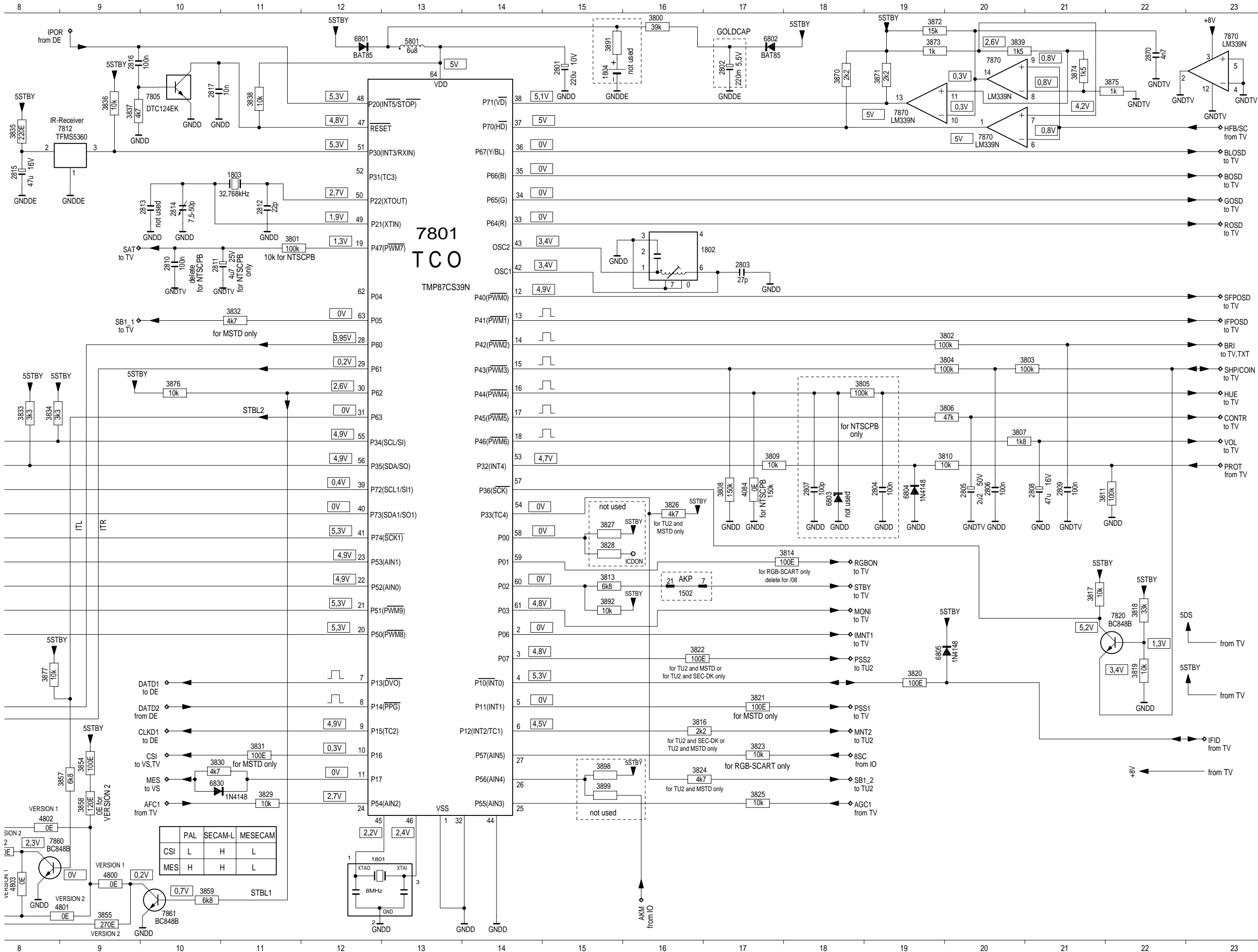

- 1502 E 2
- 1502 G16
- 1801 K12
- 1802 C17
- 1803 B11
- 1804 A15
- 1850 G 1
- 1851 G 3
- 1852 H 3
- 1853 H 1
- 1854 H 4
- 1855 G 4
- 1856 H 2
- 1857 G 4
- 1858 H 4
- 1859 G 1
- 1860 G 2
- 1861 G 3
- 1907 K 1
- 1908 J 1
- 2801 A15
- 2802 A17
- 2803 C17
- 2804 F19
- 2805 F20
- 2806 F20
- 2807 F18
- 2808 F21
- 2809 F21
- 2810 C10
- 2811 C10
- 2812 C11
- 2813 C10
- 2814 C10
- 2815 B 8
- 2816 A 9
- 2817 A10
- 2838 E 8
- 2840 B 3
- 2841 D 3
- 2842 D 2
- 2843 C 1
- 2844 B 1
- 2845 D 3
- 2863 E 3
- 2870 A22
- 3800 A16
- 3801 C11
- 3802 D20
- 3803 E21
- 3804 E20
- 3805 E18
- 3806 E20
- 3807 E20
- 3808 F17
- 3809 F17
- 3810 F20
- 3811 F21
- 3812 C 1
- 3813 G15
- 3814 G18
- 3815 A 2
- 3816 H16
- 3817 G21
- 3818 H22
- 3819 H22
- 3820 H19
- 3821 H17
- 3822 H16
- 3823 H17
- 3824 J16
- 3825 J17
- 3826 F16
- 3827 G15
- 3828 G15
- 3829 J11
- 3830 J10
- 3831 H11
- 3832 D11
- 3833 E 8
- 3834 E 8
- 3835 B 8
- 3836 A 9
- 3837 A 9
- 3838 A11
- 3839 A20
- 3840 D 8
- 3841 C 7
- 3842 C 3
- 3843 D 2
- 3844 C 2
- 3845 D 1
- 3846 B 1
- 3847 C 1
- 3850 B 2
- 3851 A 2
- 3852 A 3
- 3853 J 7
- 3854 J 9
- 3855 K 9
- 3856 J 7
- 3857 J 9
- 3858 J 9
- 3859 K10
- 3862 K 8
- 3863 E 4
- 3864 E 4
- 3865 E 6
- 3866 E 6
- 3867 E 7
- 3868 I 6
- 3869 I 5
- 3870 A18
- 3871 A19
- 3872 A19
- 3873 A19
- 3874 A21
- 3875 A22
- 3876 E10
- 3877 H 8
- 3878 J 6
- 3879 J 5
- 3881 A15
- 3882 H15
- 3888 J15
- 3889 J15
- 4081 A 1
- 4082 A 1
- 4084 F17
- 4800 K 9
- 4801 K 9
- 4802 J 8
- 4803 K 8
- 4804 K 3
- 4805 A 2
- 4806 A 3
- 4807 A12
- 4808 F18
- 4809 F19
- 4810 H19
- 4811 J10
- 4812 K13
- 4813 C13
- 4814 B 8
- 4815 E 5
- 4816 B 6
- 4817 K10
- 4818 B 23
- 4819 B20
- 4820 B19
- 4821 K 5

Signal-Chassis – IN/OUT (IO)

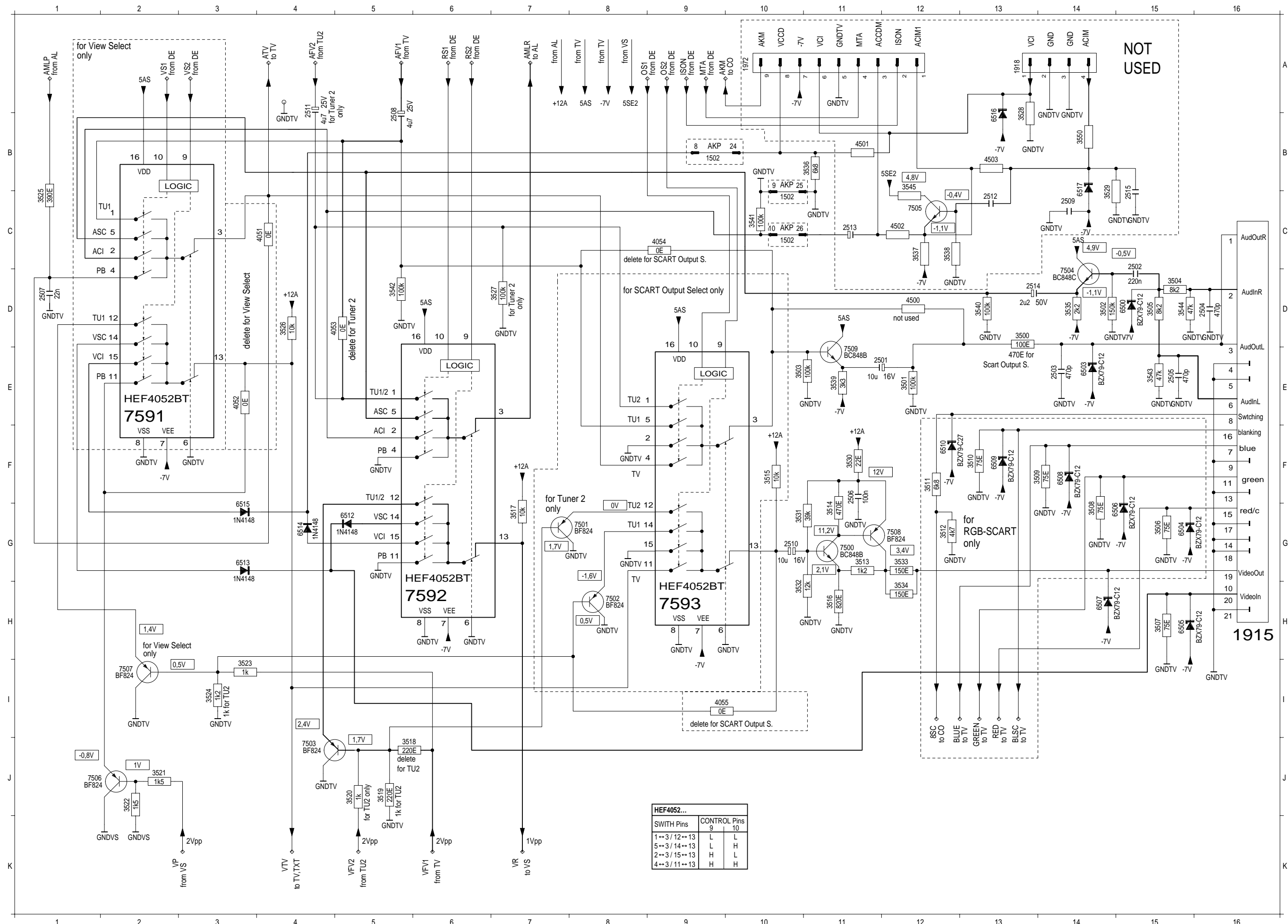

- 1502 B 9
- 1502 C10
- 1502 C10
- 1915 H16
- 1918 A13
- 1972 A10
- 2501 E11
- 2502 D15
- 2503 E14
- 2504 D16
- 2505 E15
- 2506 F11
- 2507 D 1
- 2508 B 5
- 2509 C10
- 2510 G14
- 2511 A 4
- 2512 C13
- 2513 C11
- 2514 D13
- 2515 C15
- 3500 D13
- 3501 E12
- 3502 D14
- 3503 E10
- 3504 D15
- 3505 D15
- 3506 G15
- 3507 H15
- 3508 G14
- 3509 F14
- 3510 F13
- 3511 F12
- 3512 G11
- 3513 G12
- 3514 G11
- 3515 F10
- 3516 H11
- 3517 G 7
- 3518 J 5
- 3519 J 5
- 3520 J 5
- 3521 J 2
- 3522 J 2
- 3523 I 3
- 3524 I 3
- 3525 C 1
- 3526 D 4
- 3527 D 7
- 3528 B13
- 3529 C14
- 3530 F11
- 3531 H10
- 3532 C12
- 3533 H12
- 3534 D14
- 3535 D14
- 3536 B11
- 3537 C12
- 3538 C12
- 3539 E11
- 3540 D13
- 3541 C10
- 3542 D 5
- 3543 E15
- 3544 D15
- 3545 B12
- 3550 B14
- 4051 C 4
- 4052 E 3
- 4053 D 5
- 4054 C 9
- 4055 I 9
- 4500 D12
- 4501 B11
- 4502 C12
- 4503 B13
- 4504 D15
- 4505 B13
- 4506 G15
- 4507 H14
- 4508 F14
- 4509 F13
- 4510 F12
- 4512 G 3
- 4514 G 4
- 4515 G 3
- 4516 B13
- 4517 B14
- 4518 G 8
- 4519 E 2
- 4520 H 5
- 4521 H 9

GRUNDIGErsatzteilliste
Spare Parts List

D Btx * 32700 #

6 / 96

TVR 3701 SV

SACH-NR. / PART NO.: 77250-012.52 77250-015.52 * 77250-016.52 **
BESTELL-NR. / ORDER NO.: G.CD 4352 G.CD 6352 G.CD 6452

POS. NR. POS. NO.	ABB. FIG.	SACHNUMMER PART NUMBER	ANZ. QTY.	BEZEICHNUNG D	DESCRIPTION GB
0001.000	4	75988-019.19		GEHAEUSEVORDERTEIL	CABINET FRONT ASSY
0001.500	4	75988-017.01		CASSETTENFACHKLAPPE	LIFT FLAP ASSY
0001.600	4	75988-012.02		SCHENKELFEDER	LEG SPRING
0001.700	4	75988-015.01		SCHRIFTZUG GRUNDIG	GRUNDIG-LABEL
0002.000	4	75988-015.03	4	SCHRAUBE F. BILDROEHRE	SCREW FOR PICTURE TUBE
0005.000	4	75988-015.06	4	KABELKLEMME	CABLE CLAMP
0005.100		75988-022.55		ANTENNE	ANTENNA
0005.700		75988-017.45		HALTER, FERNBEDIENUNG	HOLDER, REMOTE CONTROL
0008.000	4	75988-017.02		LAUTSPRECHERGITTER RECHTS KPL.	SPEAKER GRILLE RIGHT ASSY
0009.000		75988-017.03		LAUTSPRECHERGITTER LINKS KPL.	SPEAKER GRILLE LEFT ASSY
0018.000	4	75988-022.52		RUECKWAND	REAR PANEL
0021.000	4	75988-022.53		ABDECKUNG KPL. SCART	COVER CPL. SCART
0022.000	4	75988-022.54		KNOPF, EIN/AUS	KNOB, ON/OFF
0023.000	4	75988-015.10		DRUCKFEDER	PRESSURE SPRING
0024.000	Δ	75988-017.86		NETZKABEL 14"PAL+/59	POWER CABLE 14"PAL+/59
0028.000	4	75988-015.11	2	LAUFWERKHALTER, VORNE	TAPE DRIVE HOLDER, FRONT
0029.000	4	75988-015.12		LAUFWERKHALTER, HINTEN	TAPE DRIVE HOLDER, REAR
0031.000	4	8114-990-022	6	PLASTITE-SHR 3,5X16	SCREW 3.5X16
0033.000	1	27599-005.08		KOPFRAD 2/0 PAL	HEAD DISC 2/0 PAL
0034.000	1	75988-001.33		SCANNERMOTOR 2/0	SCANNERMOTOR 2/0
0035.000	4	75988-018.18	2	SCHRAUBE, AUDIO SUPPORT	SCREW, AUDIO SUPPORT
0040.000	Δ	27599-004.07		KOPFVERSTAERKER OHA 2/0	HEAD AMPLIFIER OHA 2/0
	Δ	75988-025.00	X	ECO-LW WDB 2/0	ECO TAPE DRIVE WDB 2/0
	Δ	75988-018.53	X	KEIN E-TEIL LEISTUNGS-CHASSIS PLSP 14 (LEISTUNGS-CHASSIS, BILDROHRPLATTE)	NO SPARE PART POWER CHASSIS PLSP 14 (POWER CHASSIS, PICTURE TUBE BOARD)
	Δ	27599-101.32	X	KEIN E-TEIL SIGNALCHASSIS PSSMG1/GV	NO SPARE PART SIGNAL CHASSIS PSSMG1/GV
	Δ	27599-101.33	X	KEIN E-TEIL SIGNALCHASSIS PSSMG3/GV *	NO SPARE PART SIGNAL CHASSIS PSSMG3/GV *
	Δ	27599-101.34	X	KEIN E-TEIL SIGNALCHASSIS PSSMG2/GV **	NO SPARE PART SIGNAL CHASSIS PSSMG2/GV **
0153.000		75988-017.06		FERNBEDIENGEBER TVP762	REMOTE CONTROL TVP 762
1010.000		75988-017.97		LAUTSPRECHER 8 OHM 3 W	SPEAKER 8OHM 3W
1100.000	Δ 4	75988-017.07		BILDROEHRE A34 JLL 90X74W	CRT A34JLL90X74W
5000.000	Δ	75988-017.08		ENTMAGNETISIERUNGSSPULE	DEGAUSSING COIL
8001.000		75988-017.09		FLEX.LEITUNG L3-1901 (7P)	FLEX. CABLE, L3-1901 7P.
8002.000		75988-017.10		FLEX.LEITUNG L8-1900 (2P)	FLEX. CABLE, L8-1900 2P.
8003.000		75988-012.13		FLACHBANDKABEL,L1-F4/1904 (6P)	FLAT FLEX CABLE,L1-F4/1904 6P.
8004.000		75988-017.47		FLEX.LEITUNG L4-1903 (3P)	FLEX. CABLE, L4-1903 3P.
8005.000		75988-017.11		FLEX.LEITUNG L2-1905(15P)	FLEX. CABLE, L2-1905 15P.
8006.000		75988-017.12		FLEX.LEITUNG 1941-1902 (10P)	FLEX. CABLE, 1941-1902 10P.
8007.000		75988-017.13		FLEX.LEITUNG LSP-1914(2P)	FLEX. CABLE, LSP-1914 2P.
8008.000		75988-017.14		FLEX.LEITUNG 1913-1967(5P)	FLEX. CABLE, 1913-1967 5P.
8011.000		75988-017.15		FLEX.LEITUNG 1912-1923(7P)	FLEX. CABLE, 1912-1923 7P.
8012.000		75988-017.16		FLEX.LEITUNG 1911-1922(5P)	FLEX. CABLE, 1911-1922 5P.
8013.000		75988-017.18		FLEX.LEITUNG 1909-1921(13P)	FLEX. CABLE, 1909-1921 13P.
8014.000		75988-324.35		FLEX.LEITUNG HA-SC	FLEX. CABLE, HA-SC
		72010-524.70		BEDIENUNGSANLEITUNG D//E/P	INSTRUCTION MANUAL D//E/P
		72010-524.71		BEDIENUNGSANLEITUNG N/L/F *	INSTRUCTION MANUAL N/L/F *
		72010-524.72		BEDIENUNGSANLEITUNG S/N/DK/SF **	INSTRUCTION MANUAL S/N/DK/SF **
		72010-524.95		SERVICE MANUAL D/GB	SERVICE MANUAL D/GB
		72010-524.96		SERVICE MANUAL ERG. D/GB	SERVICE MANUAL SUPP. D/GB
				X = SIEHE GESONDERTE E-LISTE	X = SEE SEPARATE PARTS LIST

GRUNDIGErsatzteilliste
Spare Parts List

D Btx * 32700 #

6 / 96

LEISTUNGS CHASSIS PLSP14
POWER CHASSIS PLSP14

SACH-NR. / PART NO.: 75988-018.53

ALLE NICHT AUFGEFUEHRTEN E-TEILE
SIEHE E-LISTE LEISTUNGS-CHASSIS 75988-018.53ALL PARTS NOT LISTED REFER TO
PARTS-LIST POWER CHASSIS 75988-018.50

POS. NR. POS. NO.	SACHNUMMER PART NUMBER	BEZEICHNUNG DESCRIPTION	POS. NR. POS. NO.	SACHNUMMER PART NUMBER	BEZEICHNUNG DESCRIPTION
D 6343	75988-009.33	DIODE BZX 79 C 9 V 1			
D 6568	8309-200-021	DIODE BAV21 ITT/ TFK			
L 5901	75988-021.19	SPULE 10U PM5 SPT0508			
L 5902	75988-000.24	SPULE A04 330MUH			
R 3341	Δ 75988-019.22	MSW NB 0207 5,6 OHM 5%			
SI 1372	Δ 75988-025.36	SICHERUNG RAD.T2.5A 250V			

Es gelten die Vorschriften und Sicherheitshinweise gemäß dem Service Manual "Sicherheit", Sach-Nummer 72010-800.00, sowie zusätzlich die eventuell abweichenden, landesspezifischen Vorschriften!

The regulations and safety instructions shall be valid as provided by the "Safety" Service Manual, part number 72010-800.00, as well as the respective national deviations.

GRUNDIG

Ersatzteilliste
Spare Parts List



D Btx * 32700 #

6 / 96

ALLE NICHT AUFGEFÜHRTE E-TEILE
SIEHE E-LISTE SIGNAL CHASSIS 75988-018.70

ALL PARTS NOT LISTED REFER TO
PARTS-LIST SIGNAL CHASSIS 75988-018.70

SIGNAL CHASSIS PSSMG1/GV

SACH-NR. / PART NO.: 27599-101.32

POS. NR. POS. NO.	ABB. FIG.	SACHNUMMER PART NUMBER	ANZ. QTY.	BEZEICHNUNG D	DESCRIPTION GB
1916.000		75988-017.55		KOPFHOERERBUCHSE	EAR PHONE SOCKET

POS. NR. POS. NO.	SACHNUMMER PART NUMBER	BEZEICHNUNG DESCRIPTION
D 6863	75988-017.77	LE DIODE TLHR 4605
F 1745	75988-035.72	FILTER CER 5,5 MHZ
IC 7410	75988-019.26	IC TMP 91C242AN BTVD1-2P
IC 7840	75988-009.37	IC SDA 5642-5
L 5402	75988-000.25	SPULE 0,33 MUH PM20
L 5840	75988-000.23	SPULE 6MUH8 PM10

POS. NR. POS. NO.	SACHNUMMER PART NUMBER	BEZEICHNUNG DESCRIPTION
S 1852	75988-018.03	SCHALTER
SI 1002	Δ 75988-005.30	KLEINSTSICHERUNG 630 MA/T
T 7504	8301-006-848	SMD-TRANS.BC 848 C
T 7762	8301-006-848	SMD-TRANS.BC 848 C

6 / 96

ALLE NICHT AUFGEFÜHRTE E-TEILE
SIEHE E-LISTE SIGNAL CHASSIS 75988-018.70

ALL PARTS NOT LISTED REFER TO
PARTS-LIST SIGNAL CHASSIS 75988-018.70

SIGNAL CHASSIS PSSMG3/GV

SACH-NR. / PART NO.: 27599-101.33

POS. NR. POS. NO.	ABB. FIG.	SACHNUMMER PART NUMBER	ANZ. QTY.	BEZEICHNUNG D	DESCRIPTION GB
1916.000		75988-017.55		KOPFHOERERBUCHSE	EAR PHONE SOCKET

POS. NR. POS. NO.	SACHNUMMER PART NUMBER	BEZEICHNUNG DESCRIPTION
D 6863	75988-017.77	LE DIODE TLHR 4605
F 1745	75988-035.72	FILTER CER 5,5 MHZ
IC 7801	75988-019.25	IC TMP 87CS39N
IC 7840	75988-009.37	IC SDA 5642-5
L 5402	75988-000.25	SPULE 0,33 MUH PM20
L 5840	75988-000.23	SPULE 6MUH8 PM10

POS. NR. POS. NO.	SACHNUMMER PART NUMBER	BEZEICHNUNG DESCRIPTION
S 1852	75988-018.03	SCHALTER
SI 1002	Δ 75988-005.30	KLEINSTSICHERUNG 630 MA/T
T 7504	8301-006-848	SMD-TRANS.BC 848 C
T 7762	8301-006-848	SMD-TRANS.BC 848 C

GRUNDIG

Ersatzteilliste
Spare Parts List



D Btx * 32700 #

6 / 96

ALLE NICHT AUFGEFÜHRTE E-TEILE
SIEHE E-LISTE SIGNAL CHASSIS 75988-018.70

ALL PARTS NOT LISTED REFER TO
PARTS-LIST SIGNAL CHASSIS 75988-018.70

SIGNAL CHASSIS PSSMG2/2GV

SACH-NR. / PART NO.: 27599-101.34

POS. NR. POS. NO.	ABB. FIG.	SACHNUMMER PART NUMBER	ANZ. QTY.	BEZEICHNUNG D	DESCRIPTION GB
1916.000		75988-017.55		KOPFHOERERBUCHSE	EAR PHONE SOCKET

POS. NR. POS. NO.	SACHNUMMER PART NUMBER	BEZEICHNUNG DESCRIPTION
D 6863	75988-017.77	LE DIODE TLHR 4605
IC 7410	75988-019.26	IC TMP 91C242AN BTVD1-2P
L 5402	75988-000.25	SPULE 0,33 MUH PM20
L 5840	75988-000.23	SPULE 6MUH8 PM10
S 1852	75988-018.03	SCHALTER
SI 1002	Δ 75988-005.30	KLEINSTSICHERUNG 630 MA/T
T 7504	8301-006-848	SMD-TRANS.BC 848 C
T 7762	8301-006-848	SMD-TRANS.BC 848 C

POS. NR. POS. NO.	SACHNUMMER PART NUMBER	BEZEICHNUNG DESCRIPTION
----------------------	---------------------------	----------------------------

Es gelten die Vorschriften und Sicherheitshinweise gemäß dem Service Manual "Sicherheit", Sach-Nummer 72010-800.00, sowie zusätzlich die eventuell abweichenden, landesspezifischen Vorschriften!



The regulations and safety instructions shall be valid as provided by the "Safety" Service Manual, part number 72010-800.00, as well as the respective national deviations.